



ENGINE

Model	FPT F5BFL413B
Emissions Certification	Tier 4 Final
Type	Diesel 4-stroke, Turbocharged
Cylinders	4
Bore/Stroke	3.90 x 4.33 in (99 x 110 mm)
Displacement	207 in ³ (3.4 L)
Fuel injection	Direct, high pressure common rail – HPCR
Fuel	Diesel
Engine speeds*	RPM
Rated speed – full load	2200
Low idle	900 – 1000
High idle – no load	2330 – 2430
Horsepower @ 2200 RPM:	
Gross	110 hp (82 kW)
Net	108 hp (81 kW)
Maximum torque @ 1400 RPM:	
Gross	339 lb-ft (460 N-m)
Net	338 lb-ft (459 N-m)
Torque rise at rated speed	29% +/- 5%
Radiator:	
Core type	Square wave
Core size area	486 in ² (3 145 cm ²)
Rows of tubes	4
Viscous fan:	
Style	9 blade viscous suction
Diameter	19.68 in (500 mm)
Ratio	1.4:1
Pump operating angle ratings:	
Side to side	Rated 35°
Fore and aft	Rated 35°
Oil filtration	Replaceable, full flow cartridge

NOTE: *Engine speeds w/ standard transmission.
Meets federal emission regulations.

DRIVETRAIN

Transmission – standard:
PowerDrive H-Type, 4F-4R hydraulic clutch
shifting w/ auto shift mode and direct drive

Gear ratios	Forward/Reverse	
1st	5.533/4.549	
2nd	3.359/2.762	
3rd	1.532/1.260	
4th	0.811/0.667	

Travel speeds – Standard H-Type PowerDrive		
DD Transmission	Forward	Reverse
	mph (kph)	mph (kph)
1st	4.0 (6.5)	4.8 (7.7)
2nd	6.6 (10.6)	7.8 (12.6)
3rd w/ DD Feature Off	13.7 (22.0)	16.4 (26.4)
3rd w/ DD	14.4 (23.1)	16.4 (26.4)
4th w/ DD Feature Off	23.0 (37.0)	27.6 (44.4)
4th w/ DD	25.0 (40.2)	27.6 (44.4)

Torque converter ratio 2.2

Limited slip differential – 4WD

Front 4WD/Rear axle:	
Differential ratio	2.3/2.5
Planetary hub ratio	6.0/6.4
Total reduction ratio	13.7/16.0

Service brakes:
Individually applied, power assisted,
hydraulically actuated, maintenance-free,
self-adjusting, outboard mounted, wet disc,
2 per side.
Total disc area 384 in² (0.25 m²)

Parking brakes Trans Mounted
spring-applied hydraulic release – SAHR

NOTE: Travel speeds at 2295 engine
RPM specified: w/ 21.0 L x 24.0 tires.

ELECTRICAL

Voltage	12 Volts, negative ground
Alternator	160 amp
Dual batteries:	850 cold-cranking amps each
Power plugs – 2	30 amps total

OPERATOR ENVIRONMENT

ROPS/FOPS certified protective canopy;
Anti-vandalism cover for dash – w/ canopy
only; Rear fenders extensions; Coat hook w/
garment strap; Interior rearview convex mirror;
Mechanical suspension seat – 180° swivel – Vinyl;
3 in (76 mm) retractable seat belt; Cup holder/
storage tray mounted on left-hand fender;
Right-hand storage compartment w/ lid,
tilt-steering wheel on cab models.

Gauges:
Engine water temperature; Converter oil
temperature; Fuel level; Tachometer/
hourmeter; DEF level.

Warning lights:
Air cleaner restriction; Alternator; A/C high
pressure; Cold start; Engine oil pressure;
Hydraulic oil filter bypass; Parking brake
engagement; Low fuel; Water in fuel; Low DEF.

Audible alarms w/ diagnostics:
Coolant temperature; Engine oil pressure;
Parking brake engagement; Converter oil
temperature; Shuttle engagement/seat
position; Backup alarm; Low DEF.

Horn Dual switched front and rear

OPERATING WEIGHT

Configuration – SAE Transport:

No Operator, 4:1 Loader Bucket, E-hoe, 2 Door
Cab w/ Heat and AC, 1,100 lb counter weight,
Fully fueled, Heavy Lift, PowerDrive transmission,
air seat, ride control, pilot backhoe controls,
4WD w/driveshaft guard, 21 L – 24 Rear tires.
20,760 lb (9 417 kg)

Add-on weights:

Cab-over canopy	309 lb (140 kg)
Fabricated stabilizer pads	141 lb (64 kg)
Extendahoe®	286 lb (130 kg)

HYDRAULICS

Pump: Bosch Rexroth Series 31 Variable Displacement Axial Piston Pump	
Main relief pressure:	
Standard	3,450 +/- 50 psi (238 +/- 3.5 bar)
Power Lift	3,780 +/- 50 psi (261 +/- 3.5 bar)
Filtration: 7 micron, full flow replaceable cartridge on return line, condition indicator light for filter.	
Oil cooler	Heavy-duty
Loader flow @ rated engine RPM: 41 gpm @ 2,340 psi (156.2 L/min @ 161 bar)	
Loader control valve w/ pilot or manual backhoe controls: Two or three-spool closed center sectional control valve. Single lever manual control for lift and tilt functions. The three-spool valve uses a proportional Electro-Hydraulic control for the auxiliary function. The lift lever has a positive hold "Float" position and a "return-to-dig" feature.	
Loader auxiliary hydraulics w/ proportional thumb switch w/ detent on loader control handle: 0 – 41 gpm (0 – 156.2 L/min)	
Backhoe flow @ rated engine RPM: 41 gpm @ 3,100 psi (156.2 L/min @ 214 bar)	
Manual backhoe control valve: Seven-spool monoblock open center control valve w/ eighth spool bolt-on sections. Features "Pro-Control" which includes custom designed spools for each individual function along w/ "swing cushioning" valve for zero-wag swing control. Basic control valve has an open center parallel circuit for all functions.	

Pilot backhoe control valve:
Seven or eight spool sectional closed center control valve. Features "Pro-Control" which includes custom designed spools for each individual function along w/ "swing cushioning" valve for zero-wag swing control. Basic control valve is closed center, w/ circuits in parallel w/ a post-compensated, flow sharing feature for simultaneous operation of all circuits.

1-way flow auxiliary hydraulics:

1-way-flow hydraulic valve is equipped w/ an adjustable LS relief valve to control attachment pressure and a 6 position flow control selector for 6 detented, distinct flow settings.

Actuation:

Manual backhoe controls – cab floor pedal
Pilot controls – left-hand joystick

2-way flow auxiliary hydraulics:

Actuation:

Activate the 2-way flow switch located on the rear console
Manual shift – 2-way flow linkage on far right of backhoe tower
Pilot controls – left-hand joystick.

Front axle:	
4WD Differential	9.1 qt (8.6 L)
4WD Planetaries – each	1.1 qt (1.0 L)
Rear axle:	
Differential and planetaries	19.7 qt (18.6 L)
Engine oil w/ filter	
	8.5 qt (8.0 L)
Cooling system:	
w/ heater	19.0 qt (18.0 L)
w/o heater	18.3 qt (17.3 L)
Window washer reservoir	
	3.0 qt (2.8 L)

OTHER SPECIFICATIONS

Front tires:	
4WD	12.5/80 x 18.0, 10-ply rating
Rear tires:	
4WD	21.0 L x 24.0, 10-ply rating
Turning radius*: Curb to Curb:	
4WD – engaged:	
Brakes on	12 ft 0 in (3.65 m)
Brakes off	14 ft 11 in (4.54 m)
4WD – disengaged:	
Brakes on	11 ft 3 in (3.43 m)
Brakes off	13 ft 6 in (4.11 m)

NOTE: *Turning radius dimensions curb to curb w/ 21.0 L x 24.0 rear tires.

SERVICE CAPACITIES

Fuel tank	35.0 gal (132.0 L)
DEF tank	3.6 gal (13.5 L)
Hydraulic system:	
Total w/ Extendahoe®	131 qt (123.6 L)
Reservoir w/ filter	55.4 qt (52.4 L)
Reservoir w/o filter	53.4 qt (50.5 L)
Transmission – total system:	
4WD PowerDrive H-Type	19 qt (18.0 L)

LOADER BUCKET SIZES

Type	Width	Weight	Struck	Heaped Capacity
Long Lip Bucket with bolt-on edge	93 in (2.36 m)	1,188 lb (539 kg)	1.1 yd ³ (0.84 m ³)	1.29 yd ³ (0.99 m ³)
4 IN 1® Bucket with bolt-on edge	93 in (2.36 m)	1,685 lb* (764 kg)	1.0 yd ³ (0.76 m ³)	1.20 yd ³ (0.92 m ³)

NOTE: *Weight of 4 IN 1® bucket includes edges, cylinders and tube lines.

BACKHOE BUCKET SIZES

Type	Width	Weight	Heaped Capacity
Universal Buckets	12 in (305 mm)	295 lb (134 kg)	3.40 ft ³ (0.10 m ³)
	18 in (457 mm)	356 lb (162 kg)	5.30 ft ³ (0.15 m ³)
	24 in (610 mm)	427 lb (194 kg)	7.70 ft ³ (0.22 m ³)
	30 in (762 mm)	489 lb (222 kg)	10.20 ft ³ (0.29 m ³)
	36 in (914 mm)	552 lb (251 kg)	12.70 ft ³ (0.36 m ³)
High Capacity Buckets	24 in (610 mm)	447 lb (203 kg)	8.50 ft ³ (0.24 m ³)
	30 in (762 mm)	502 lb (228 kg)	10.60 ft ³ (0.30 m ³)

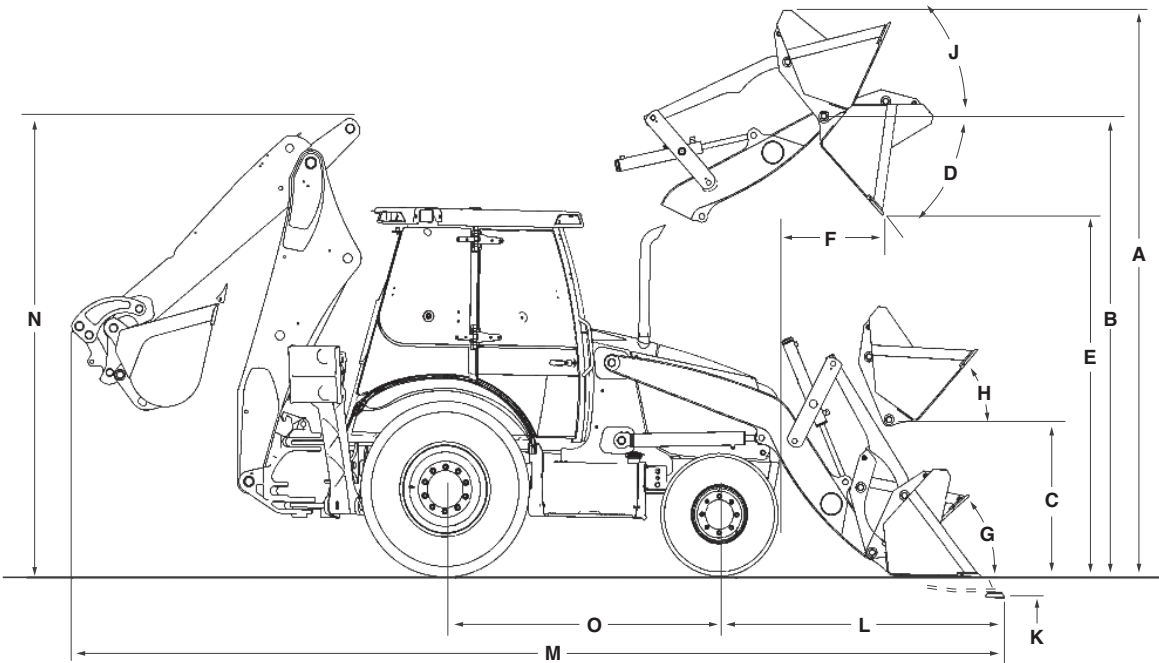

Line drawings are for illustrative purpose only and may not be exact representation of unit.

LOADER DIMENSIONS

	Long Lip Bucket	4 IN 1® Bucket
A. Overall operating height – fully raised	13 ft 11 in (4.24 m)	13 ft 10 in (4.22 m)
Height to:		
B. Bucket hinge pin fully raised	11 ft 6 in (3.50 m)	11 ft 6 in (3.50 m)
C. Bucket hinge pin at SAE carry	12.75 in (324 mm)	12.75 in (324 mm)
D. Dump angle at full height	45°	45°
E. Dump clearance at full height, 43° dump:		
Bucket	8 ft 11 in (2.73 m)	9 ft 1 in (2.77 m)
Clam open	–	9 ft 11 in (3.01 m)
F. Dump reach at full height, 45° dump – from bumper:		
Bucket	27.0 in (685 mm)	27.0 in (685 mm)
Clam open	–	13.9 in (353 mm)
Bucket rollback:		
G. @ Groundline	40°	41°
H. @ SAE carry	46°	46°
J. @ Full height	Adjustable	Adjustable
K. Digging depth below grade:		
Bucket flat	6.1 in (156 mm)	5.9 in (151 mm)
Clam open – dozing	–	3.5 in (88 mm)
L. Reach from front axle centerline – bucket on ground	6 ft 9 in (2.05 m)	6 ft 6 in (1.99 m)
Lift capacity to full height – calculated values	8,425 lb (3 822 kg)	8,025 lb (3 640 kg)
Breakout force:		
Lift cylinders	11,450 lb (5 093 daN)	11,241 lb (5 000 daN)
Dump cylinders	10,873 lb (4 837 daN)	11,674 lb (5 193 daN)
Bucket cutting edge width	94.2 in (2.39 m)	93.0 in (2.36 m)
Maximum grading angle	106°	106°
Maximum clam opening	–	38.3 in (972 mm)
Moldboard height	–	36.8 in (934 mm)
Raising time to full height	3.7 sec	3.7 sec
Bucket dumping time	2.0 sec	2.0 sec
Lowering time:		
Power down	2.5 sec	2.5 sec
Return-to-dig – manual controls/pilot controls	3.6 sec	3.0 sec
Clam:		
Open time	–	1.3 sec
Close time	–	1.1 sec

NOTE: Loader dimensions taken with 4WD, 21.0 L x 24.0 rear tires.

DIMENSIONS

	Extendahoe®	
	Retracted	Extended
M. Overall transport length:		
Long Lip bucket	23 ft 4 in (7.11 m)	–
4 IN 1® bucket	23 ft 1 in (7.04 m)	–
Overall transport width	8 ft 6 in (2.59 m)	–
Height – 4WD with 21.0 L x 24.0 tires:		
To top of canopy	8 ft 11 in (2.70 m)	8 ft 11 in (2.70 m)
To top of cab	8 ft 11 in (2.73 m)	8 ft 11 in (2.73 m)
To top of exhaust stack	8 ft 9 in (2.67 m)	8 ft 9 in (2.67 m)
N. Transport	11 ft 7 in (3.53 m)	–
Ground clearance at backhoe frame	14.8 in (377 mm)	14.8 in (377 mm)
Angle of departure	18.6°	18.6°
Wheel tread:		
12.5/80 x 18.0	75.6 in (1.92 m)	75.6 in (1.92 m)
21.0 L x 24.0	69.6 in (1.77 m)	69.6 in (1.77 m)
Width over tires:		
12.5/80 L x 18.0	88.2 in (2.24 m)	88.2 in (2.24 m)
21.0 L x 24.0	91.8 in (2.33 m)	91.8 in (2.33 m)
O. Wheelbase:		
21.0 L x 24.0	84.5 in (2.15 m)	84.5 in (2.15 m)

CYLINDERS

	Bore Diameter	Rod Diameter	Stroke	Closed Length
Loader:				
Lift – 2	3.50 in (88.9 mm)	1.88 in (47.6 mm)	29.13 in (740.0 mm)	41.54 in (1 055.0 mm)
Dump – 2	3.00 in (76.2 mm)	1.50 in (38.1 mm)	20.33 in (516.5 mm)	29.90 in (759.5 mm)
4 IN 1® clam – 2	3.00 in (76.2 mm)	1.75 in (44.5 mm)	9.08 in (230.6 mm)	19.62 in (498.3 mm)
Backhoe:				
Boom	5.00 in (127.0 mm)	2.50 in (63.5 mm)	38.25 in (971.6 mm)	52.82 in (1 341.6 mm)
Dipperstick	4.75 in (120.7 mm)	2.50 in (63.5 mm)	25.14 in (628.5 mm)	39.65 in (1 007.0 mm)
Bucket	3.50 in (88.9 mm)	2.50 in (63.5 mm)	35.35 in (897.9 mm)	48.17 in (1 223.6 mm)
Extendahoe®	3.00 in (76.2 mm)	1.75 in (44.5 mm)	42.05 in (1 068.0 mm)	56.22 in (1 428.0 mm)
Swing – 2	4.00 in (101.6 mm)	2.00 in (50.8 mm)	11.50 in (292.0 mm)	24.44 in (620.8 mm)
Stabilizer – 2	5.25 in (133.4 mm)	2.50 in (63.5 mm)	20.40 in (518.1 mm)	33.57 in (852.7 mm)

AXLE RATINGS

	Front – 4WD	Rear
Maximum static	67,883 lb (30 791 kg)	70,848 lb (32 136 kg)
Dynamic operating	47,426 lb (21 512 kg)	49,494 lb (22 450 kg)
Static operating	18,969 lb (8 604 kg)	19,798 lb (8 980 kg)
Oscillation – front axle	22° total – 11° side to side	22° total – 11° side to side

BACKHOE LIFT CAPACITIES

	Extendahoe®			
	Retracted		Extended	
	Standard	Power Lift	Standard	Power Lift
Boom Lift	Lift Capacity lb (kg)	Lift Capacity lb (kg)	Lift Capacity lb (kg)	Lift Capacity lb (kg)
+16 ft (4.87 m)	—	—	2,115 (959)	2,447 (1 110)
+14 ft (4.27 m)	2,837 (1 287)	3,282 (1 489)	2,395 (1 086)	2,769 (1 256)
+12 ft (3.66 m)	3,201 (1 452)	3,701 (1 679)	2,536 (1 151)	2,935 (1 331)
+10 ft (3.05 m)	3,281 (1 488)	3,797 (1 722)	2,593 (1 176)	3,001 (1 361)
+8 ft (2.44 m)	3,263 (1 480)	3,783 (1 716)	2,564 (1 163)	2,972 (1 348)
+6 ft (1.83 m)	3,213 (1 457)	3,732 (1 693)	2,549 (1 156)	2,961 (1 343)
+4 ft (1.22 m)	3,146 (1 427)	3,662 (1 661)	2,521 (1 144)	2,935 (1 331)
+2 ft (0.61 m)	3,077 (1 396)	3,590 (1 628)	2,489 (1 129)	2,904 (1 317)
Ground Level	3,018 (1 369)	3,528 (1 600)	2,489 (1 129)	2,904 (1 317)
-2 ft (0.61 m)	2,965 (1 345)	3,474 (1 576)	2,466 (1 118)	2,882 (1 307)
-4 ft (1.22 m)	2,935 (1 331)	3,446 (1 563)	2,446 (1 109)	2,866 (1 300)
-6 ft (1.83 m)	2,938 (1 333)	3,455 (1 567)	2,443 (1 108)	2,869 (1 301)
-8 ft (2.44 m)	3,007 (1 364)	3,541 (1 606)	2,465 (1 118)	2,899 (1 315)
-10 ft (3.05 m)	3,175 (1 440)	3,685 (1 671)	2,530 (1 148)	2,979 (1 351)
-12 ft (3.66 m)	—	—	2,707 (1 228)	3,187 (1 446)
-14 ft (4.27 m)	—	—	3,239 (1 469)	3,759 (1 705)
Dipper Lift				
+14 ft (4.27 m)	—	—	4,281 (1 942)	4,281 (1 942)
+12 ft (3.66 m)	5,618 (2 548)	5,618 (2 548)	4,046 (1 835)	4,046 (1 835)
+10 ft (3.05 m)	5,399 (2 449)	5,399 (2 449)	3,984 (1 807)	3,984 (1 807)
+8 ft (2.44 m)	5,360 (2 431)	5,360 (2 431)	3,913 (1 775)	3,913 (1 775)
+6 ft (1.83 m)	6,030 (2 735)	6,030 (2 735)	4,166 (1 889)	4,166 (1 889)
+4 ft (1.22 m)	7,203 (3 267)	7,203 (3 267)	4,102 (1 861)	4,102 (1 861)
+2 ft (0.61 m)	—	—	4,850 (2 200)	4,850 (2 200)

NOTE: Boom and Dipper Lift Capacities are rated per SAE J31 and are 87% of the maximum hydraulic lift force available with the specified options.

BACKHOE OPERATIONAL DATA

	Extendahoe®	
	Retracted	Extended
Digging depth:		
Maximum	14 ft 6 in (4.43 m)	18 ft 0 in (5.48 m)
Maximum with hi-capacity bucket	15 ft 1 in (4.59 m)	18 ft 6 in (5.64 m)
2 ft (610 mm) flat bottom	14 ft 5 in (4.39 m)	17 ft 11 in (5.45 m)
8 ft (2.44 m) flat bottom	13 ft 5 in (4.09 m)	17 ft 1 in (5.22 m)
Overall reach from:		
Rear axle centerline	21 ft 11 in (6.68 m)	25 ft 4 in (7.71 m)
Swing pivot	18 ft 3 in (5.56 m)	21 ft 8 in (6.60 m)
Loading height	12 ft 0 in (3.66 m)	14 ft 4 in (4.38 m)
Loading reach	4 ft 8 in (1.42 m)	7 ft 3 in (2.22 m)
Swing arc	180°	180°
Bucket rotation:		
Mechanical coupler	198.0°	198.0°
Hydraulic coupler – Extendahoe® dipper	194.8°	194.8°
Hydraulic coupler – standard dipper	198.0°	198.0°
Stabilizer spread – operating:		
Flip pad	10 ft 9 in (3.28 m)	10 ft 9 in (3.28 m)
Cast pad	11 ft 1 in (3.38 m)	11 ft 1 in (3.38 m)
Digging force:		
Bucket cylinder – SAE rated 3,460 psi	13,795 lb (61 363 N)	13,795 lb (61 363 N)
Bucket cylinder – Power Lift	15,070 lb (67 039 N)	15,070 lb (67 039 N)
Dipper cylinder – SAE rated 3,460 psi	8,657 lb (38 508 N)	6,305 lb (28 045 N)
Dipper cylinder – Power Lift	9,458 lb (42 071 N)	—
Leveling angle:		
Flip pad	11.5°	11.5°
Cast pad	12.4°	12.4°

NOTE: Lift capacities apply straight to the rear of prime mover. Equipped with 24 in (610 mm) Universal heavy-duty trenching bucket and Case coupler except as noted.

STANDARD EQUIPMENT

OPERATOR ENVIRONMENT

See page 1

ENGINE

FPT F5BFL413B diesel
Selective Catalytic Reduction – SCR
Full flow engine oil filter
Aspirated air cleaner – replaceable dual element dry type with radial seal
Fuel filter with water trap
Radiator with overflow bottle
Antifreeze to -34° F (-37° C)
Electronic throttles – foot and rotary hand
Self-adjusting belt
High Pressure Common Rail computer controlled injection with diagnostic features
Engine ECO Mode – Detent on backhoe hand throttle, push button switch on dash
Auto Engine Idle
Auto Engine Shutdown
Auto Protection Shutdown
Electronic Fuel Priming
Cold Weather Starting Aid:
Dual 12 volt batteries, glow plugs, engine block heater and heated CCV hose

DRIVETRAIN

PowerDrive H-Type transmission, 4F-4R, hydraulic clutch shifting, kick down, transmission disconnect and FNR switch in loader control lever, includes auto shift mode and direct drive
Front axle:
4WD heavy-duty mechanically driven front axle with 14.0 L x 17.5 tires, limited slip differential and drive shaft guard
Rear axle:
4WD heavy-duty outboard planetary drive, with 21.0 L x 24.0 tires
Torque converter – 12 in (305 mm)
On-the-go electric 4WD control
Electric F/R shuttle control
Electric differential lock control, push-button
Park brake, spring-applied, hydraulic release – SAHR
Drive shaft guard – 4WD models

HYDRAULICS

Ground level remote hydraulic test ports
Variable displacement axial piston pump
Pump:
41 gpm @ 3,000 psi
(156.2 L/min @ 207 bar)
Heavy-duty hydraulic oil cooler
7-micron, spin on oil filter

LOADER

Bucket position indicator; Lifting lugs and tie downs on standard bucket; Single lever control with self-leveling and return-to-dig; Hand operated clutch disconnects on loader and shift levers, single lever 4-function loader control: lift, dump, clutch cut-out, differential lock and FNR switch

BACKHOE

Over center design, Fabricated “S” boom; Pro Control System; Dipperstick integrated serrated gripper teeth; Case mechanical coupler; Power Lift, Power Boost
Extendahoe®
Cleated dirt stabilizer pads

OTHER

Front tire 12.5/80 x 18.0, 10-PR
Rear tire 21.0 L x 24.0, 10-PR
Forward tilt engine hood
Replaceable, molded front bumpers
Front/Rear tie downs
Reflective logos
Signal Lights – cab and canopy:
2 rear tail/stop
2 front flashers/turn
2 rear flashers/turn
Working/Driving Lights – cab and canopy:
Adjustable halogen work lights – 55 W:
4 front
2 side – one left, one right
4 rear
Master disconnect switch and remote jump-start terminals
Hydrostatic steering
Backup alarm
Vertical spin-on engine oil, fuel and hydraulic filters
Locking DEF/Fuel covers
Tool box – bolt-on, step-mounted

TELEMATICS

CASE SiteWatch™ Telematics – includes hardware and a 3-yr Advanced data subscription

WARRANTY

1-Year/Unlimited-Hour Full-Coverage Base Limited Warranty
2-Year/2,000-Hour Extended Engine Warranty

OPTIONAL EQUIPMENT

OPERATOR ENVIRONMENT

Speed selectable Auto Ride Control
Comfort Steering with two-speed steering pump and 3rd/4th gear cutout
ROPS/FOPS certified protective cab available in LH Door or 2 door with heat, A/C, defroster, door activated dome light, 4 front, 4 rear and 2 adjustable side lights, floor mat, tinted glass, bluetooth radio, front and rear wiper and fender extensions
Deluxe Cab package included on 2-door cabs includes: deluxe interior, viscous fan, pull-down sun visor and 72 dba sound level
Premium multi-color, hand stitched cloth, heated air suspension seat – not for use with ROPS Canopy option

ENGINE

Severe Cold Weather Starting Aid:
Synthetic transmission, hydraulic and engine oil – order with cold weather starting aid

LOADER

Auxiliary hydraulics for loader-mounted equipment with thumb-operated proportional control
Hydraulic front quick coupler
Tool portfolio of additional attachments
Buckets – see page 2

BACKHOE

1-way/2-way Auxiliary backhoe hydraulics for hammers, plate compactors or similar
1-way flow attachments or switch to 2-way flow for thumbs, augers or similar 2-way flow attachments
Bolt-on hardened gripper teeth
Two-lever control
Pilot operated control system:
Fingertip proportional Electro-Hydraulic stabilizer controls
Thumb-operated proportional Electro-Hydraulic Extendahoe® control
Thumb-operated horn button
Thumb-operated auxiliary hydraulic control
Infinitely adjustable towers
In-cab switchable “excavator to backhoe” control pattern change
Hydraulic bucket quick coupler
Universal coupler – CAT/Deere compatible
Flip over stabilizer pads
Buckets – see page 2
Hydraulic thumb – Includes: 2 replaceable, high strength, bolt on tines with two positions for Universal or Hi-Cap buckets – meshes with Bucket teeth on 18 in & 24 in Buckets

OTHER

Front tires:
12.5/80 x 18, 10 PR
Rear tires:
21 L x 24, 10 PR or 540/70 R24 Michelin
Special paint
LED Working/Driving Light Package:
4 front
4 rear
2 side
Front Fenders
Special Feature Request

CaseCE.com

©2020 CNH Industrial America LLC. All rights reserved. CASE is a trademark registered in the United States and many other countries, owned by or licensed to CNH Industrial N.V., its subsidiaries or affiliates. CNH Industrial Capital is a trademark in the United States and many other countries, owned by or licensed to CNH Industrial N.V., its subsidiaries or affiliates. Printed in U.S.A. Contains 10% post-consumer fiber.

IMPORTANT: CASE Construction Equipment Inc. reserves the right to change these specifications without notice and without incurring any obligation relating to such change. Availability of some models and equipment builds vary according to the country in which the equipment is used. The illustrations and text may include optional equipment and accessories and may not include all standard equipment. Your CASE dealer/distributor will be able to give you details of the products and their specifications available in your area.



CASE Construction Equipment is biodiesel-friendly. NOTE: All engines meet current EPA emissions regulations. All specifications are stated in accordance with SAE Standards or Recommended Practices, where applicable.



Always read the Operator's Manual before operating any equipment. Inspect equipment before using it, and be sure it is operating properly. Follow the product safety signs and use any safety features provided.

Form No. CCE202012580SNWT
Replaces Form No. CCE201810580SNWT

580SN WT

7 of 7